

Roraima

SERIES



CARROS Y MESAS AUXILIARES



AUXILIARY TROLLEYS AND TABLES

▶ 2.810 m

📍 5° 08'36'' N 60° 45'45''W



Somos una empresa, fundada en el año 1992, especializada en la creación y distribución de productos para clínicas y hospitales veterinarios. Tenemos una amplia cartera de productos, trabajamos con marcas líderes del sector y además somos especialistas en mobiliario veterinario y equipos de anestesia, diseñados y fabricados en exclusiva por nosotros con las técnicas más avanzadas. Nuestra dedicación al estudio y desarrollo de productos nos permite ofrecer artículos de alta calidad, para así hacer más fácil la labor del veterinario tanto en España como en el mercado internacional.



www.everest-tecnovet.com

· I + D INNOVAR PARA MEJORAR

Invertimos en investigación y desarrollo pues estamos convencidos de que estar a la vanguardia de la tecnología y del diseño trae beneficios no solo a nuestra compañía, sino también a todo el sector veterinario.

· COMPETIR AL MISMO NIVEL CON FABRICANTES MUNDIALES

Hemos logrado conquistar espacios en el mercado internacional y nuestro objetivo es mostrar que en España se diseña y fabrica equipos veterinarios de calidad similar o superior a otros equipos ya consolidados en el mercado actual mundial.

· NOTABLE EVOLUCIÓN EN NUESTRO SISTEMA DE PRODUCCIÓN

En el año 2015 ampliamos nuestras instalaciones y creamos una planta exclusiva para los trabajos de producción. Hemos generado empleo de personal altamente capacitado para poner en práctica nuestros equipos.

· COLABORACIÓN DE PROXIMIDAD

Apostamos por la colaboración de proximidad y cada vez más trabajamos junto a talleres y proveedores ubicados cerca de nosotros, acciones que impulsan la economía local y la salud del planeta. Queremos asegurarnos de la excelencia de todos nuestros equipos y de la facilidad de asistencia técnica si un día es necesario.

· SERVICIO DE ASESORAMIENTO TÉCNICO - SAT

La tecnología actual nos ha permitido dinamizar el trabajo del SAT. A través de video-llamadas, envío de fotos para ilustrar dudas, tutoriales en vídeo y nuestro canal de YouTube, asesoramos siempre que sea posible al veterinario para facilitar su labor.

· CREEMOS EN EL SECTOR, EN LAS PERSONAS QUE LO CONFORMAN

Nos preocupamos del bienestar de nuestros clientes y trabajadores y les ofrecemos pequeñas grandes soluciones que marcan la diferencia en su trabajo diario. Somos humanos y tratamos con humanos. Igual que nuestro personal, nuestros clientes nunca serán un número.

· OPORTUNIDADES PARA TODOS

Everest abre las puertas y los brazos a todos. Nuestra plantilla es variada, hay gente de todas las edades, orígenes, capacidades, mujeres y hombres por igual. Tenemos puestos para prácticas de estudiantes y que en nuestra empresa han conseguido su primer empleo.

· RESPETO AL MEDIO AMBIENTE

Tenemos una especial preocupación en cuidar el medio ambiente y la preservación de nuestro entorno. Estamos trabajando sin pausa para disminuir nuestro impacto medioambiental con la seriedad que exigen nuestros tiempos.

RORAIMA SERIES CARROS AUXILIARES

Las mesas y carros RORAIMA están diseñados para auxiliar el trabajo del veterinario por muchos años.

Durables y resistentes como todos los productos de fabricación propia EVEREST, la serie RORAIMA es garantía de calidad y funcionalidad.

Está todo pensado para el bien estar del profesional veterinario.

Estantes con y sin reborde



Cestas de plástico diferentes modelos

100% CONFIGURABLES

2 alturas:

96 cm y 160 cm

2 tipos de estantes:

con y sin reborde

3 cestas diferentes:

50, 100 y 200 mm de profundidad

Ruedas:

2 con y 2 sin freno

Construidos íntegramente en acero inoxidable, CON cestas de plástico



Ruedas
2 con y 2 sin freno



Roraima

Nuestro departamento de I+D+I ha desarrollado un nuevo concepto de carros auxiliares en que tienes la libertad de configuración según tus necesidades.

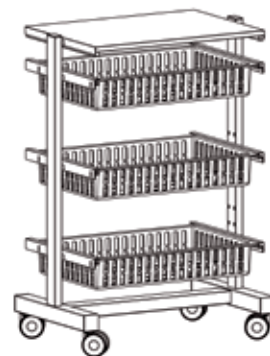
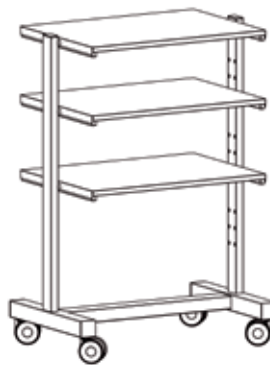
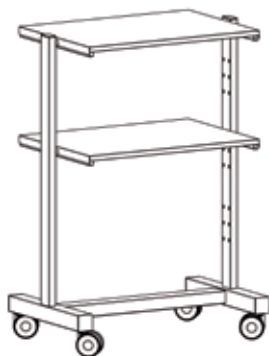
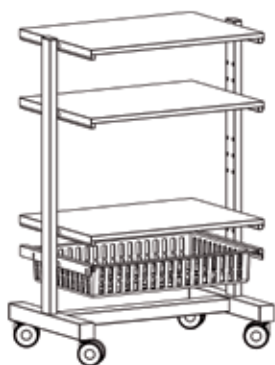

www.everest-tecnovet.com
info@everest-tecnovet.com

 **EVEREST**
tecnovet

RORAIMA SERIES CARROS AUXILIARES

100%
configurable

Configura los carros RORAIMA según tus necesidades:

BASE CARRO

Ruedas en línea
(2 con freno, 2 sin freno)
(Sin estantes ni accesorios)

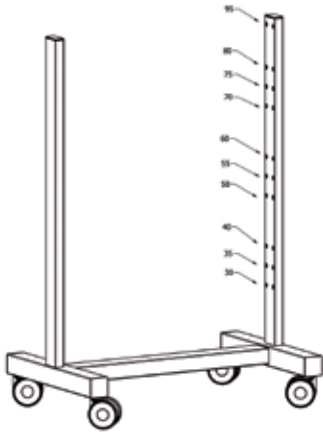

MA441201
Altura: 96 cm

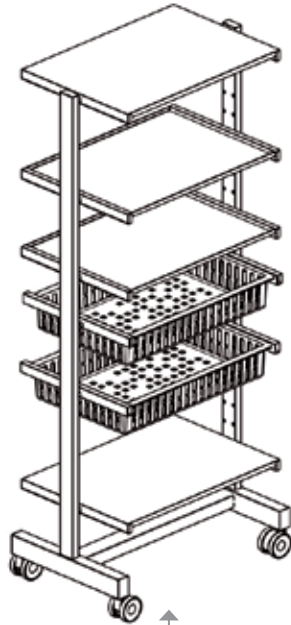

MA441202
Altura: 160

ACCESORIOS



MA441231
Estante Plana con reborde
Acero Inox 304 Satinado
640 x 420 mm



MA441230
Estante Plana sin reborde
Acero Inox 304 Satinado
640 x 420 mm



MA441250
Cesta transparente
600 x 400 mm / 50 mm



MA441251
Cesta transparente
600x400 mm / 100 mm

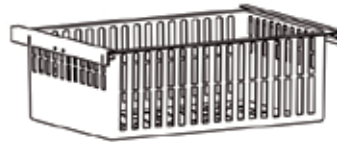

MA441252
Cesta transparente
600 x 400 mm / 200 mm



DIVISORES CESTAS



DIVISOR CESTA 50Y
MA441250A
50x400 mm

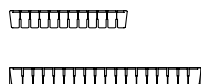

DIVISOR CESTA 100Y
MA441251A
100x400 mm

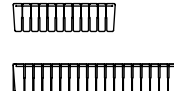

DIVISOR CESTA 200Y
MA441252A
200x400 mm

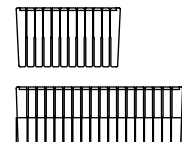

DIVISOR CESTA 50X
MA441250B
50x600 mm

DIVISOR CESTA 100X
MA441251B
100x600 mm

DIVISOR CESTA 200X
MA441252B
200x600 mm

RORAIMA SERIES MESA MAYO

The logo for Roraima, featuring the brand name in a bold, green, sans-serif font. A green horizontal line is positioned above the text, and a green vertical line is positioned to the left of the text, forming a partial frame.

Mesa quirúrgica para Instrumental.
Regulable en altura: 85 - 130 cm (con brida de seguridad)
Base en "T": Mayor libertad de posicionamiento y movimiento.
En acero Inoxidable
Bandeja grande, que respeta la norma médica.
Curva sanitaria: sin rincones, facilita la limpieza y desinfección.
Tamaños bandeja: 50 x 60 cm (útil) 53 x 65 (perfil incluido)

MI010003

BANDEJA GRANDE

Norma médica, curva sanitaria.
Sin rincones. Fácil limpieza y desinfección.

ALTURA REGULABLE
con brida de seguridad
85 - 130 cm

MEDIDAS:
53 x 65 cm (perfil incluido)
50 x 60 cm (zona útil)

BASE EN "T"
Mayor libertad
de posicionamiento
y movimiento.

**RUEDAS
RESISTENTES**
de doble llanta



Monte RORAIMA

También conocido como Tepuy

RORAIMA es una montaña que hace divisa con tres países diferentes: Brasil, Guyana y Venezuela. Su aspecto es único y espectacular. Tiene acantilados de 400 metros de altura. Es una de las formaciones geológicas más antiguas de la Tierra.

Algunas curiosidades sobre RORAIMA:

- Ha sido llamado de "La Madre de Todas las Aguas"
- Hay un estado brasileño que se llama RORAIMA
- Ha sido inspiración cinematográfica de "Mundo Perdido", "Up" de Disney y "La Distancia más larga".
- Su punto más alto es llamado "Maverik"
- El significado de RORAIMA según los pemones taurepanes: La palabra "roroi" significa "verde azulado"; y la palabra "ma" quiere decir "grande". Es el "Gran Verde azulado".

Todos los nombres de los productos de fabricación propia Everest tienen nombre de montaña. Hemos decidido nombrar nuestra serie de mesas y carros auxiliares RORAIMA por su superficie tan plana que nos remite a una mesa y por hacer nuestro homenaje particular a tal Maravilla.

Roraima

▶ 2.810 m

📍 5° 08'36'' N 60° 45'45'' W

Brasil, Guyana y Venezuela





Gracias por su interés en nuestros productos.

Confiamos en que esta información le sea de utilidad.

Para cualquier cuestión, estamos a su disposición.

No dude en contactar con su agente comercial o a través del teléfono **+34 936 686 715** o correo electrónico info@everest-tecnovet.com

Saludos,

Equipo Everest-Tecnovet



1992



2007



2022





We are a company, founded in 1992, specialised in the creation and distribution of veterinary products for veterinary clinics and hospitals. We have a wide range of products that include the leading brands in the veterinary industry and we are specialists in veterinary furniture and anaesthesia equipment designed and manufactured exclusively by us using the most advanced techniques. Our dedication to research and development of veterinary products allows us to offer the highest quality, in order to facilitate the work of veterinarians both in Spain and in the international market.



www.everest-tecnovet.com

- **R&D INNOVATE TO IMPROVE**

We invest in research and development as we believe that being at the forefront of technology and design not only benefits our company, but also the whole veterinary field.

- **COMPETING AT THE SAME LEVEL AS WORLD MANUFACTURERS**

We have managed to conquer a place in the international market and our aim is to show that in Spain we design and manufacture veterinary equipment of similar or superior quality to other equipment already consolidated in the current world market.

- **SIGNIFICANT EVOLUTION IN OUR PRODUCTION SYSTEM**

In 2015 we expanded our facilities and created a plant exclusively for production. We have generated employment of highly qualified personnel to implement our equipment.

- **CLOSE COOPERATION**

We are committed to local collaboration and increasingly work with workshops and suppliers located close to us, actions that boost the local economy and the health of the planet. We want to ensure the excellence of all our equipment and the ease of technical assistance should it ever become necessary.

- **TECHNICAL ADVISORY SERVICE - SAT**

Today's technology has allowed us to streamline the work of the SAT. Through video calls, sending photos illustrating doubts, tutorial on videos and our YouTube channel, we provide advise to veterinarians whenever possible to facilitate their work.

- **WE BELIEVE IN THE SECTOR, IN THE PEOPLE WHO ARE PART OF IT.**

We care about the well-being of our customers and employees and offer them solutions that make a difference in their daily work. We are human and we deal with humans. Just like our staff, our customers will never be a number.

- **OPPORTUNITIES FOR ALL**

Everest opens its doors and arms to everyone. We have a diverse workforce, with people of all ages, backgrounds and abilities, women and men alike. We have internships for students who have found their first job in our company.

- **RESPECT FOR THE ENVIRONMENT**

We have a special concern for the environment and the preservation of our surroundings. We are working tirelessly to reduce our environmental impact with the seriousness that our times demand.

RORAIMA SERIES AUXILIARY TROLLEY

RORAIMA tables and trolleys are designed to assist veterinarians in their work for a long time.

Long lasting and resistant as all EVEREST own manufactured products, the RORAIMA series is a guarantee of quality and functionality. It has been designed and thought out for the well-being of the veterinary professional.

Estantes con y sin reborde



Different plastic baskets models

100% CONFIGURABLE

2 different heights:
96 cm and 160 cm

2 types of shelves:
with and without border

3 different baskets:
50, 100 and 200 mm deep

Wheels:
2 brake wheels,
2 unbrake wheels.

All stainless steel construction, plastic baskets



Wheels
2 brake wheels,
2 unbrake wheels.

Roraima

Our R+D+I department has developed a new concept of auxiliary trolley with which you have the freedom to customize it according to your needs. Entirely made of stainless steel..

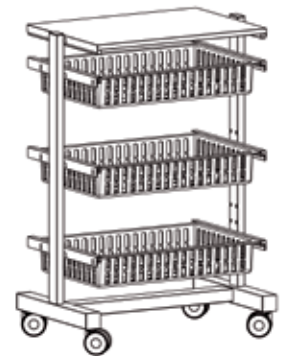
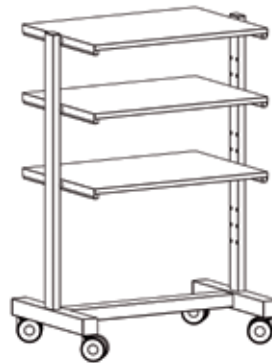
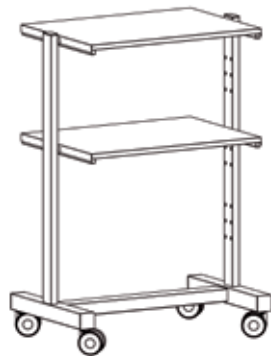
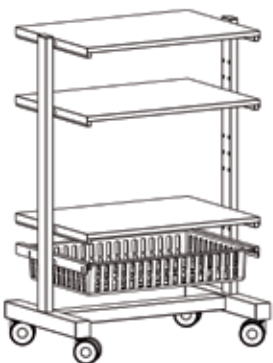

www.everest-tecnovet.com
info@everest-tecnovet.com

 **EVEREST**
tecnovet

RORAIMA SERIES AUXILIARY TROLLEY

100%
configurable

RORAIMA trolleys can be configured according to your needs

TROLLEY

Height: 96 or 160 cm
Wheels: 2 with and
2 without brakes
(no shelves or accessories)

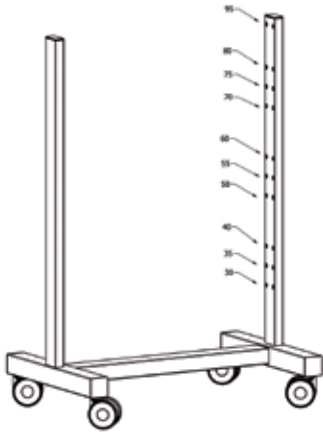

MA441201
height: 96 cm

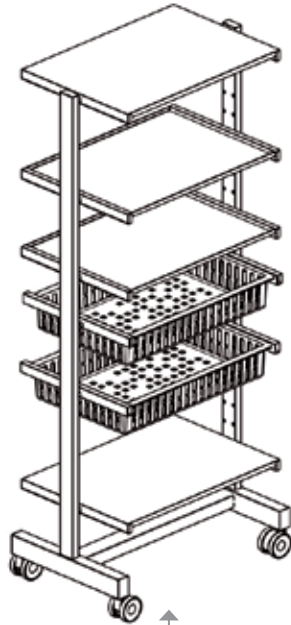

MA441202
height: 160 cm

ACCESORIOS



MA441231
Flat shelves with border
Stainless Steel 304 Satin
640 x 420 mm



MA441230
Flat shelves without border
Stainless Steel 304 Satin
640 x 420 mm



MA441250
Transparent basket
600 x 400 mm / 50 mm



MA441251
Transparent basket
600x400 mm / 100 mm

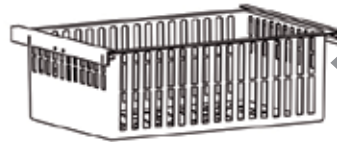

MA441252
Transparent basket
600 x 400 mm / 200 mm



BASKET DIVIDERS

50Y
MA441250A
50x400 mm

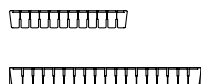

50X
MA441250B
50x600 mm

100Y
MA441251A
100x400 mm

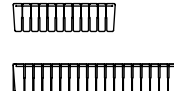

100X
MA441251B
100x600 mm

200Y
MA441252A
200x400 mm

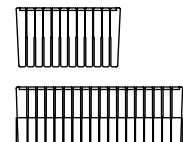

200X
MA441252B
200x600 mm

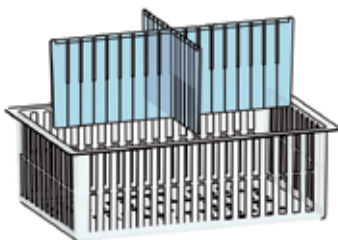

RORAIMA SERIES MAYO TABLE

Surgical Instrument Table

Height adjustable: 85-130 cm (with safety locking collar)

T-base: Greater freedom for positioning and movement.

Stainless steel

Large tray, respecting the medical standard. Sanitary cuve:

no corners, facilitating cleaning and disinfection.

Tray sizes: 50 x 60 cm (useful) 53 x 65 (profile included)

Roraima

MI010003

LARGE TRAY:

Medical standard, sanitary curve.

No corners.

Easy cleaning and disinfection.

ADJUSTABLE HEIGHT

with safety locking collar

85 - 130 cm

MEASUREMENTS:

53 x 65 cm (edge included)

50 x 60 cm (usable area)

RESISTANT WHEELS

with double rim

T-BASE

Greater freedom

for positioning

and movement.



RORAIMA Mount

Also known as Tempuy

RORAIMA is a mountain that borders three different countries: Brazil, Guyana and Venezuela. Its appearance is unique and spectacular. It has cliffs of 400 meters high. It is one of the oldest geological formations on Earth.

Some curiosities about RORAIMA:

- It has been named "Mother of All Waters"
- There is a Brazilian state named RORAIMA
- It has been the cinematic inspiration for "Lost World", "Up" by Disney and "The Longest Distance".
- Its highest point is called "Maverik"
- The meaning of RORAIMA according to the Pemón Taurepanes: The word "roro" means "blue-green"; and the word "ima" means "big". It is the "Big Blue Green".

All the names of our own manufactured Everest products have mountain names. We have decided to name our table and trolley series RORAIMA due to its flat surface that is so reminiscent of a table and for rendering our own particular homage to such a Wonder.

Roraima

▶ 2.810 m

📍 5° 08'36'' N 60° 45'45''W

Brasil, Guyana and Venezuela





Thank you for your interest in our products. We hope you find this information useful. For any question, we are at your disposal.

Do not hesitate to contact your commercial agent or by telephone **+34 936 686 715** or email info@everest-tecnovet.com

Greetings,

Everest-Tecnovet Team



1992



2007



2022